



MUSE Autumn School – Fixed Mobile Convergence



Hans Mickelsson



Multi Service Access Everywhere

Muse confidential

- > Motivation for Mobility (FMC)
- > Definitions and MUSE interpretation
- > Use Cases & Resulting Requirements
- > Challenges
- > General Architecture and relation to 3GPP
- > Conclusions

Motivation for Fixed-Mobile Convergence



McGuire's Law (Law of Mobility)



- > The value of a product increase with mobility.
- > The cost of adding mobility has come down due to Moore's law and Metacalfe's law.

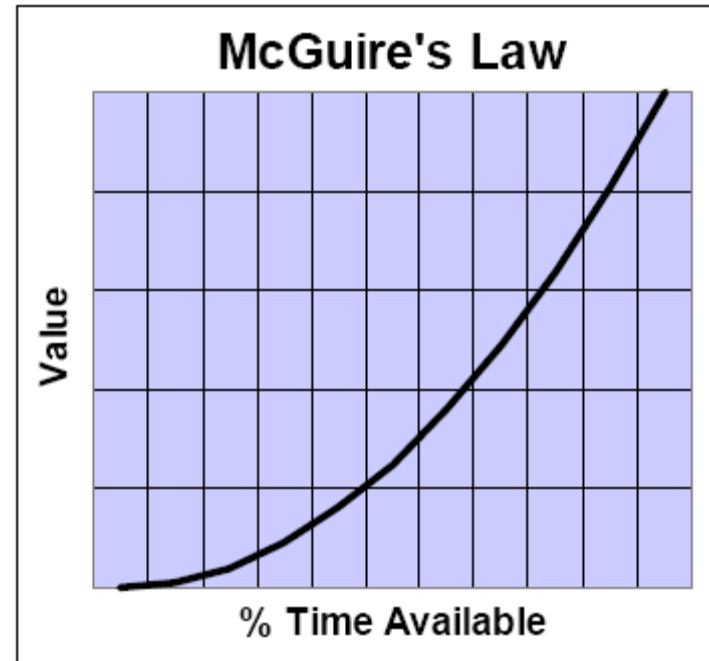
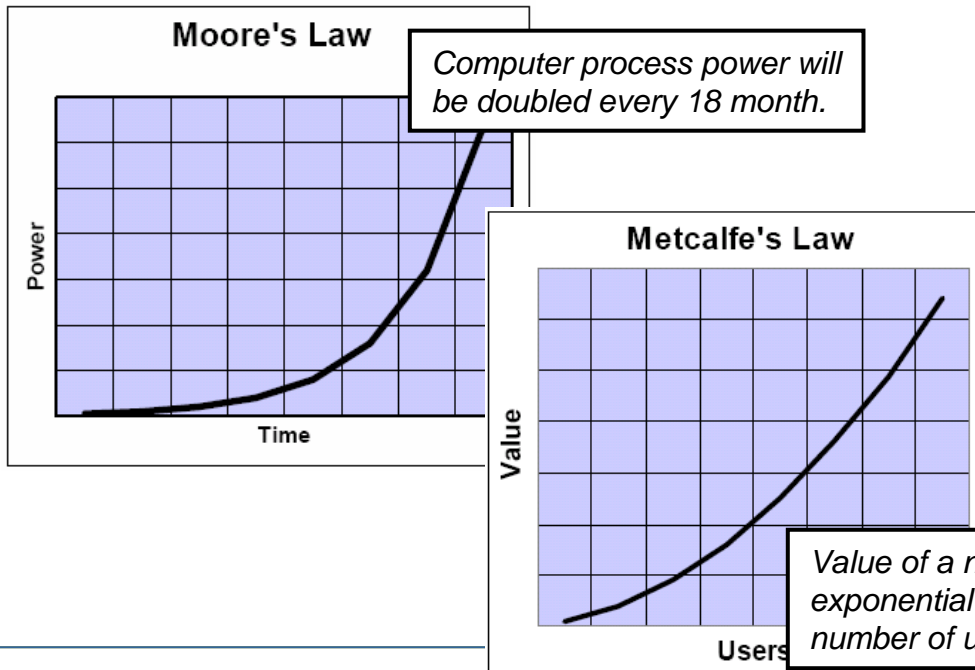

Sprint White paper

Today's broadband situation

Subscriptions tied to household

- > Desktop for Internet
- > Laptop with WLAN
- > Triple play

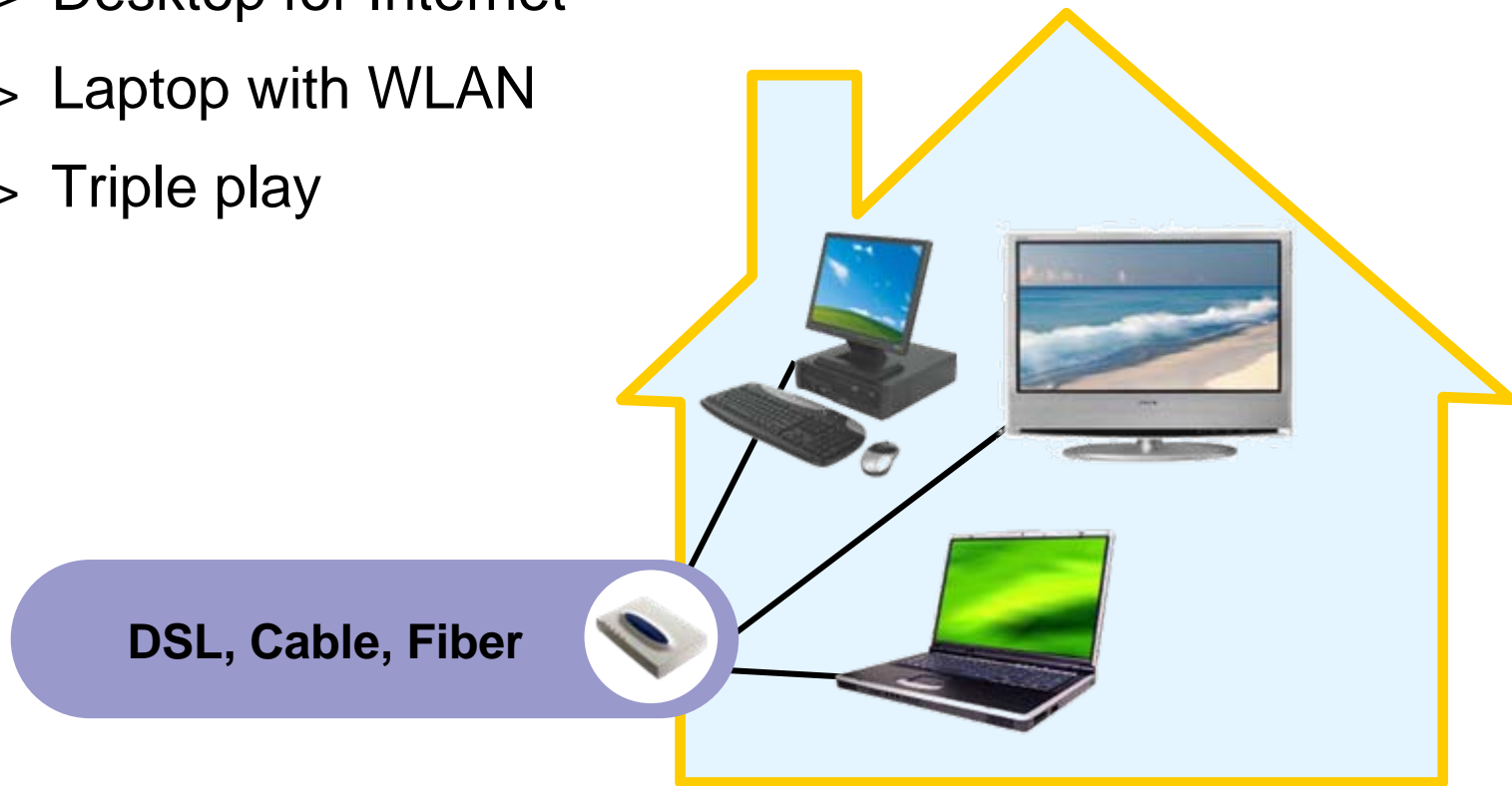

Coming soon - Portable & Personalized

Any service, anywhere, anytime



Opportunity with FMC/multi-access



- > Multiple accesses used as a competitive advantage
- > Subscriber offerings
 - Quadruple-play bundling (TV, Internet and voice + mobility)
 - New differentiating nomadic services
"Whenever, where ever"
- > Synergies
 - Maximize usage of same infrastructure for all services
 - Reuse mobile investments for fixed broadband and vice versa

Challenges with multi-access

- > Access to subscribed services at any location
 - Personalization of network services, individuals rather than household
 - Common subscriber management
 - Ensure service delivery over any access type
- > Differentiate and control subscriber traffic
 - Introduction of new unique nomadic services
 - Service aware handling of subscriber traffic
 - Flexible charging based on service and access type
- > Multi-standard environment
 - DSLF, 3GPP, IEEE, WiMAX, ETSI TISPAN
 - Terminal
- > Mobility
 - Hand-over between access technologies
 - Session continuity
 - Roaming

FMC – Possible Convergence

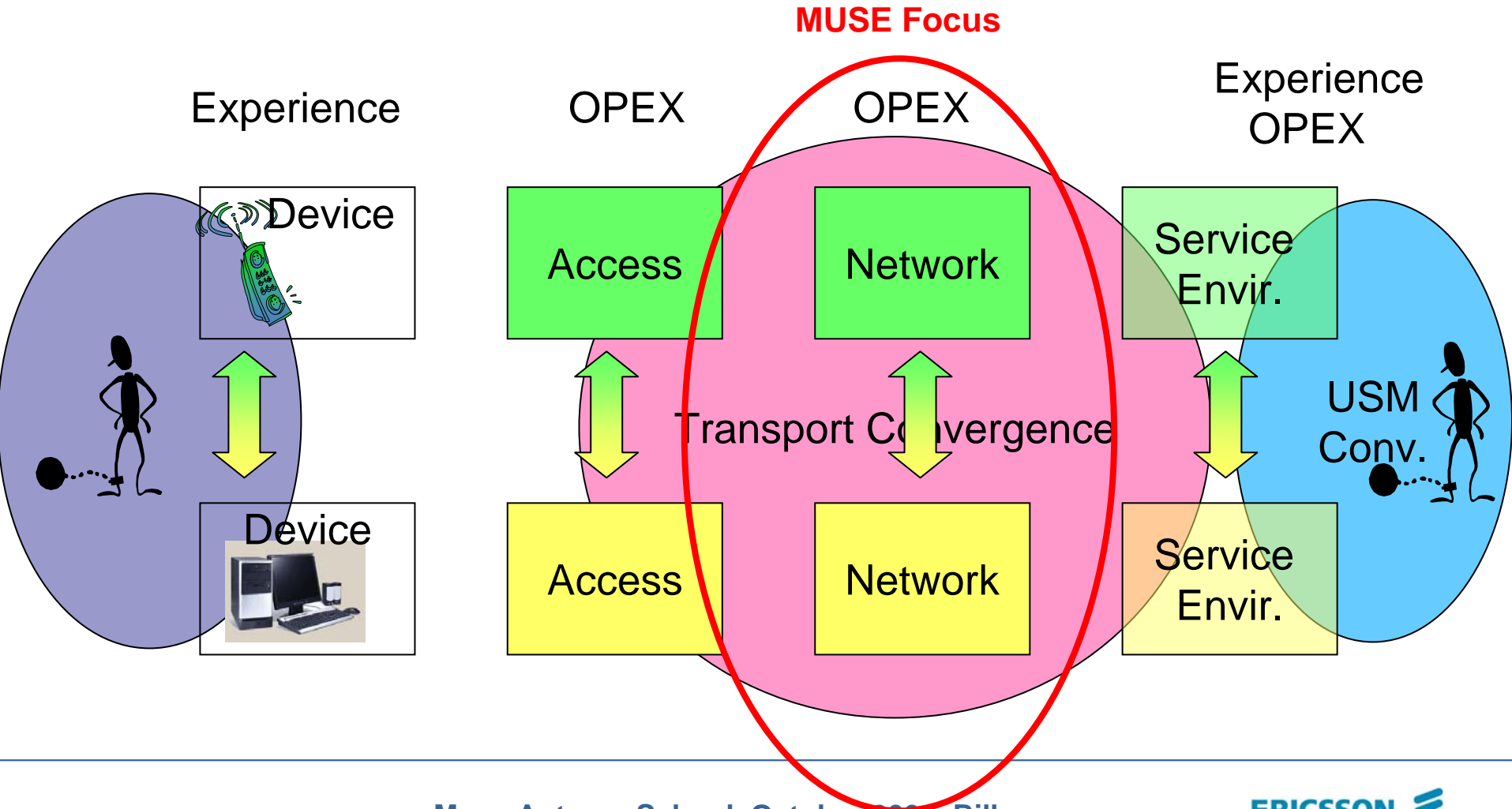

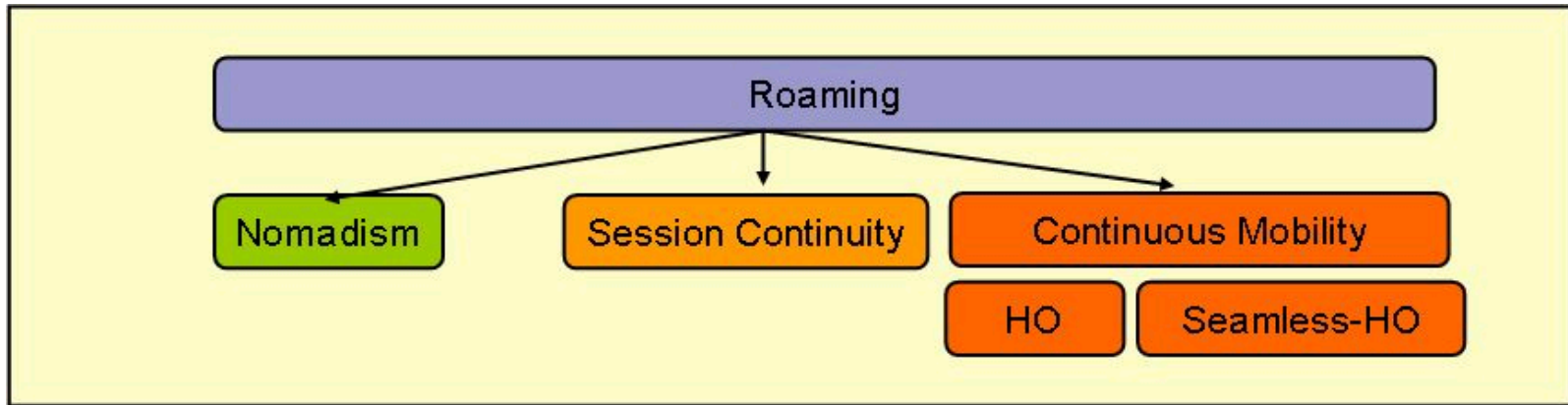

| | Movement of user or end device | Session (and Service) | Loss of data | Handover |
|----------------------------|---------------------------------------|--|----------------------------|--------------------------------|
| Nomadism | Discrete | Terminated | Not applicable | Not possible |
| Session Continuity | Continuous | Possible break/resume (continuous session) | Perceptible | Optionally |
| Continuous Mobility | Continuous | Continuous | Minimal or not perceptible | Handover/ Seamless Handover |

FMC – The MUSE Approach

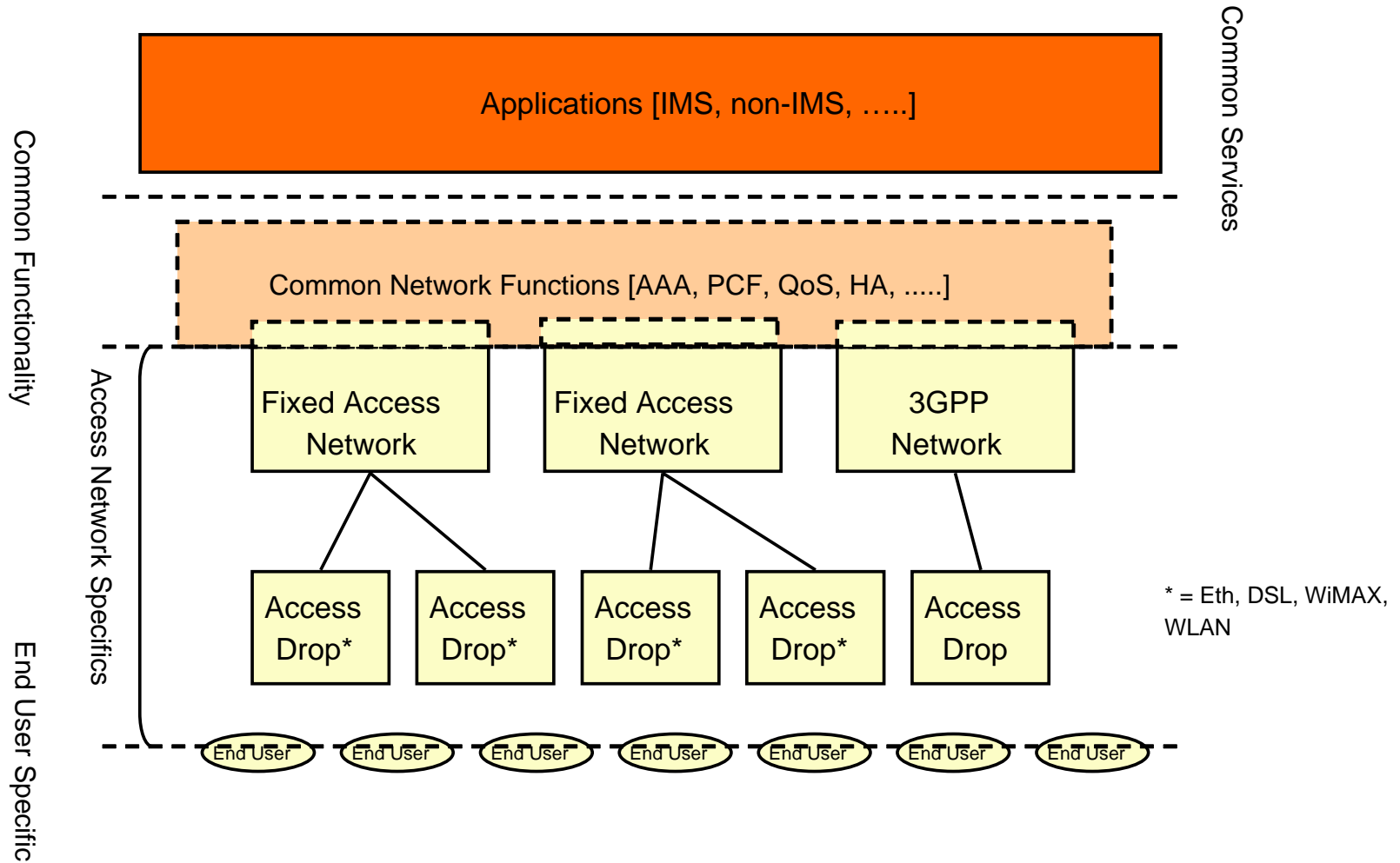

Use Cases



- > Convenience and ease of use
 - Users expect similar interfaces for the services accessed irrespectively of the network in use (fixed or mobile).

- > Always best connected
 - Users expect to always be connected at any time and to the best possible access technology and that irrespectively of where and when – even when on the move.

- > Reliability and security
 - Users expect reliability in all transactions independent of access and connection quality. The users also expect a high level of security from e.g. Spam, fraud, viruses, eavesdropping etc.

High-level view of different use cases

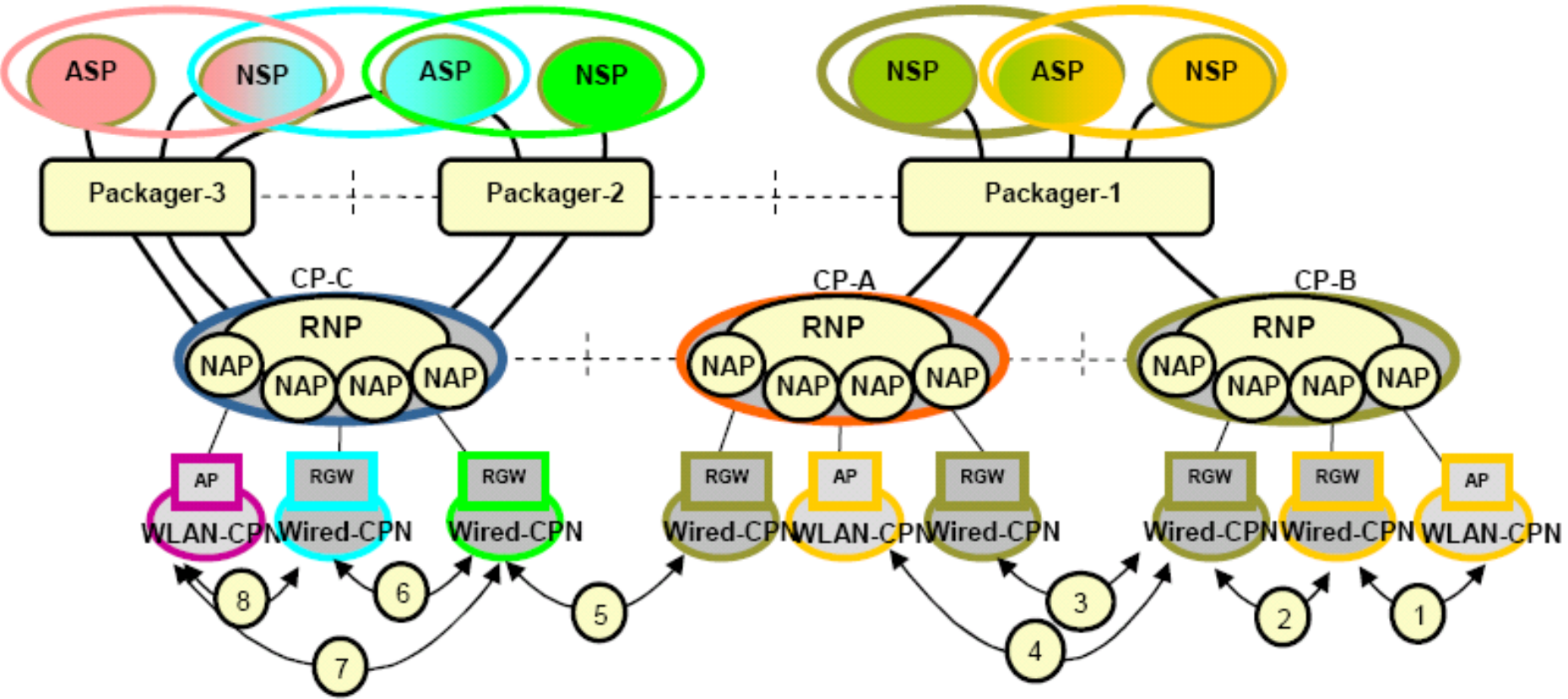

Nomadism

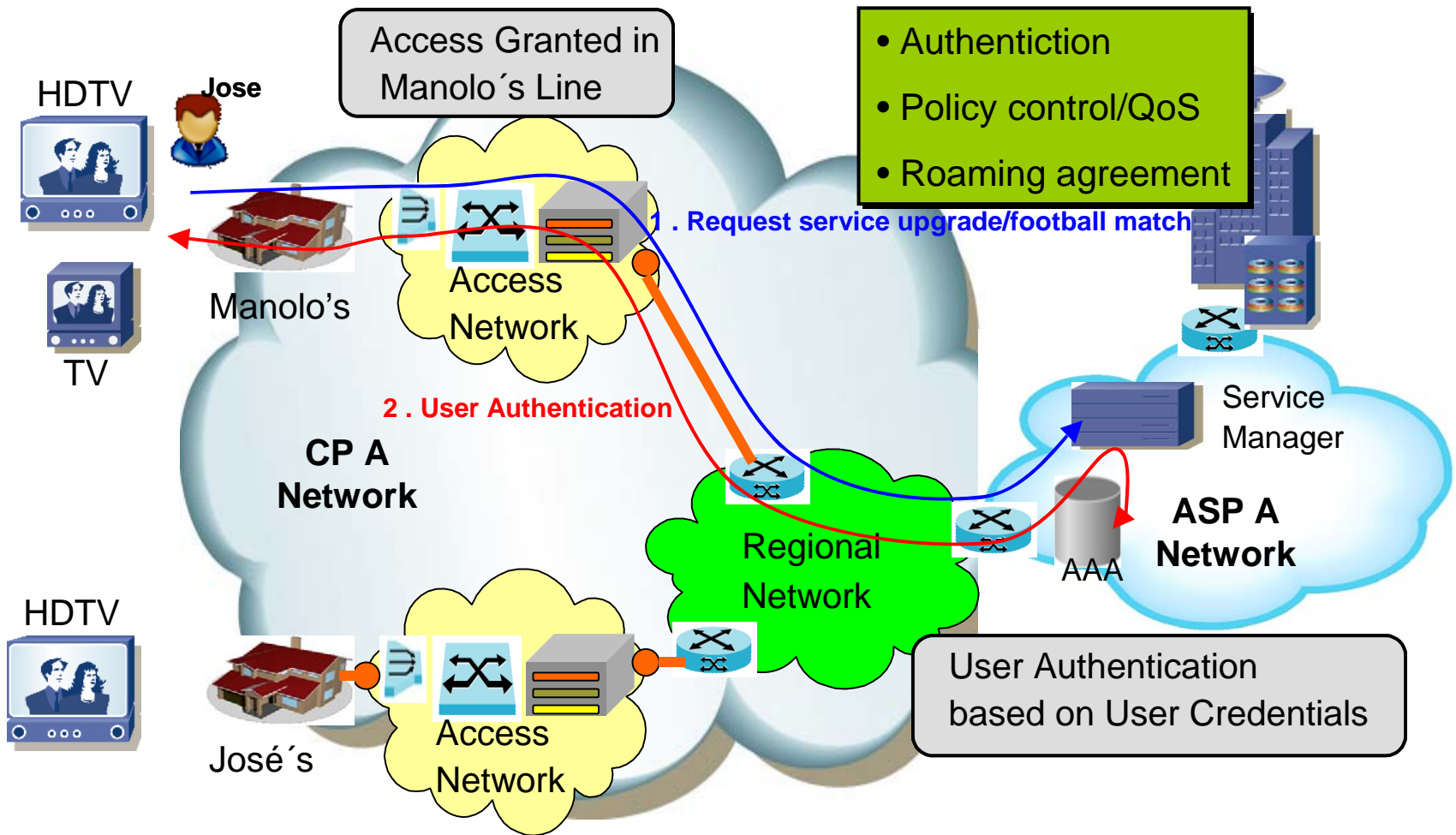

MUSE Use Case – Session Continuity

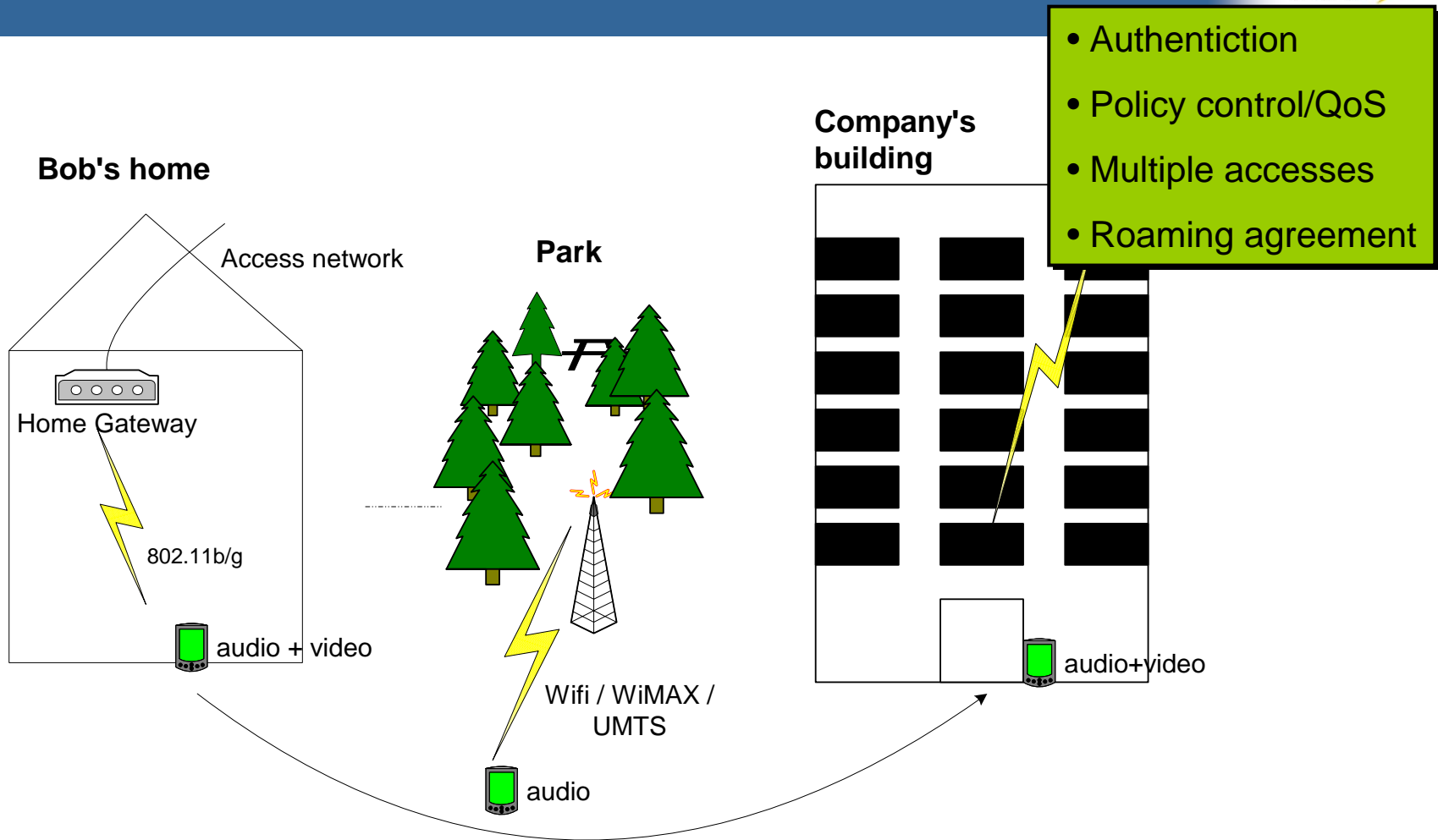

- > *Service environment policy* is related to the service set available for a nomadic user away from his home network.
- > *Multiple access to the same service*: If service environment supports, a user may use the same service from multiple different locations simultaneously.
- > *Roaming*: The users should be able to access their profile from a different access network.
- > *Media adaptation* - may be necessary when a nomadic user or device changes his connection point and the service quality or access characteristics at the new location are different.
- > *Digital Rights Management* may impose several constraints for nomadic services.

- > *Resource policy*: The visitor's resources (e.g. connection speed) can be restricted.
- > *Access rights to a domain*: A nomadic user can find two kinds of access rights in a visited domain: public or private.
- > *Network resource policy*: Network resources must be allocated and managed properly in the aggregation network for each nomadic user.
- > *Authentication, authorization and accounting (AAA)*.
- > *Security, privacy*: Network must keep security and privacy for both nomadic and local users.
- > *Network Layer Reachability*: Users and terminals must be addressable at layer 3.
- > *Location*: Network location of the user must be known by the network,

Technical Challenges



Authentication of Nomadic Services and Users

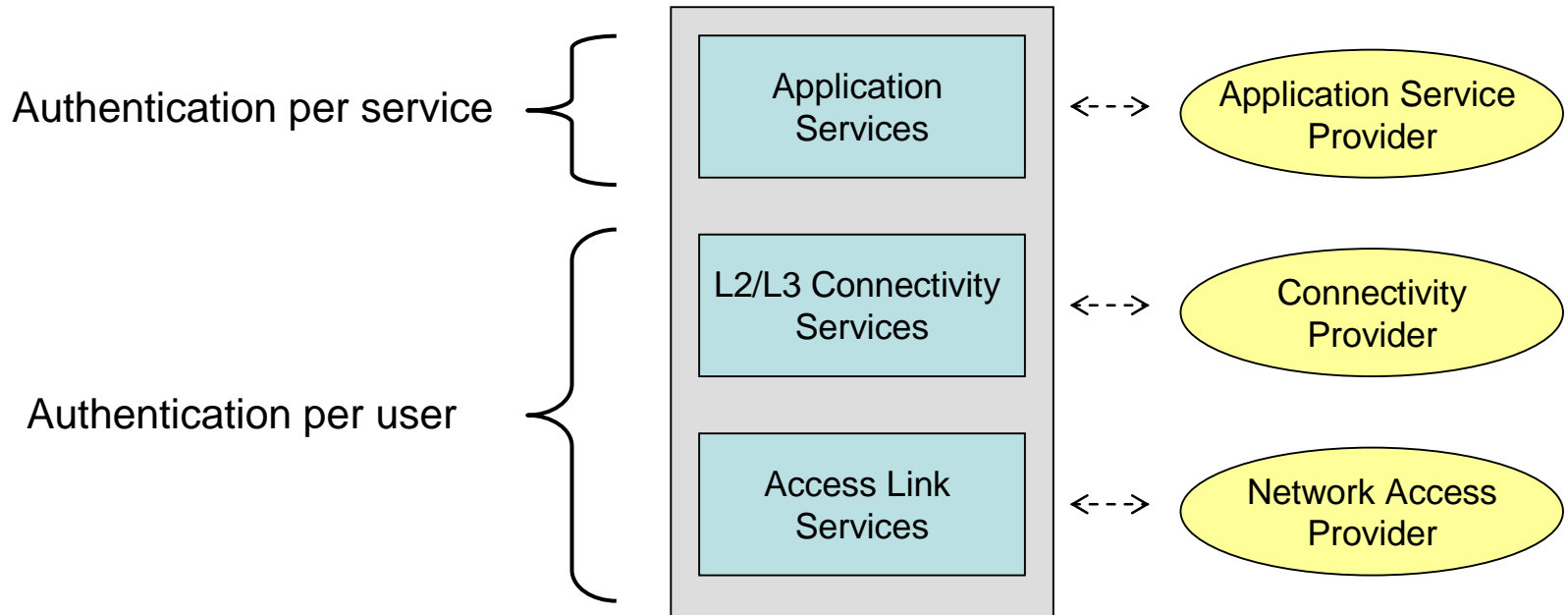

- > Trust of RGW
- > Authentication of user in visited domain

Example - Per User Authentication*

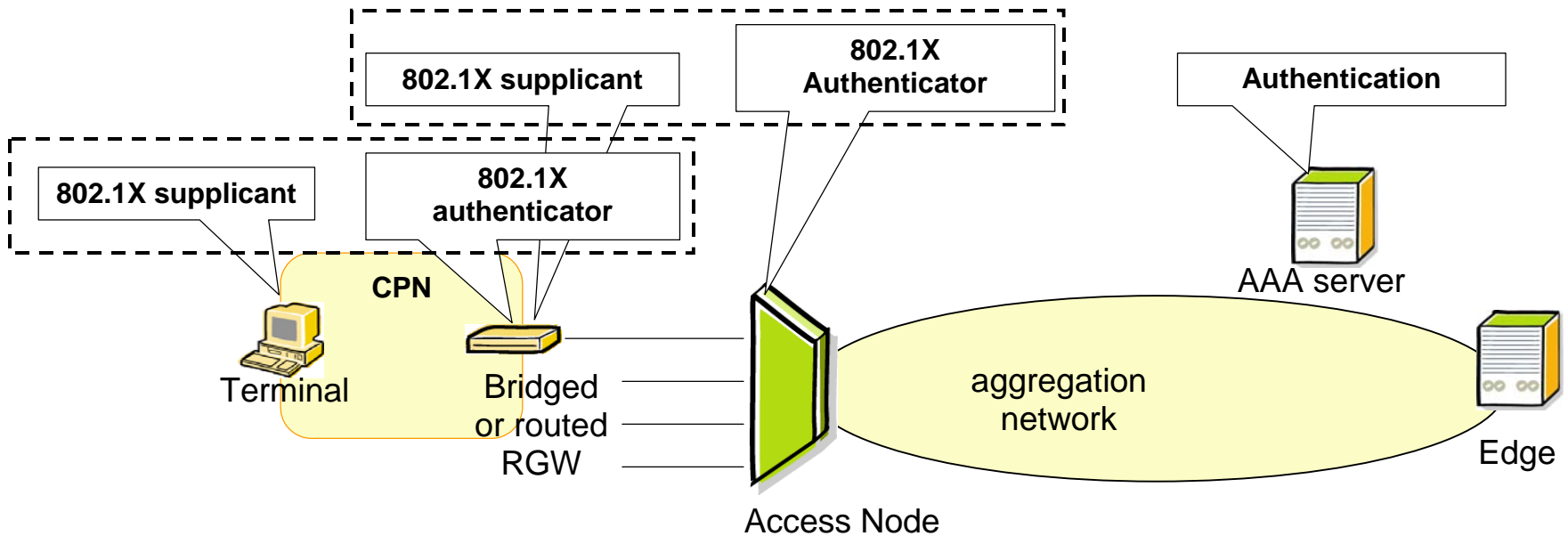

- > Credentials, e.g. xSIM is used to identify the user.
- > Protocol for carrying credentials is typically EAP

**802.1x is just an example, other protocols may also be used*

- > Session Continuity requires a fast AAA process
 - Single-sign-on to avoid sequential authentication
- > Session continuity can be implemented in two ways
 - Network layer mechanisms such as MIP hides the network attachment point from the application layer
 - Application layer signalling by means of e.g. SIP allows media flow changes
- > Both methods introduce noticeable handover disruption time, primarily due to the AAA process
- > A mobility manager concept is proposed
 - Network triggered handover
 - The mobility manager instructs the terminal when handover shall be carried out => AAA process can start prior the actual handover

- > *User policies* – describe and identify the user, describes parameters such as prioritisation within the subscribed services.
- > *Service policies* – describe network functions needed, user device requirements etc. for the subscribed services.
- > *Network policies* – QoS, Admission control, signalling policies between networks, resource management
- > *Business policies* – SLA, roaming agreements, charging etc.

Policy Control

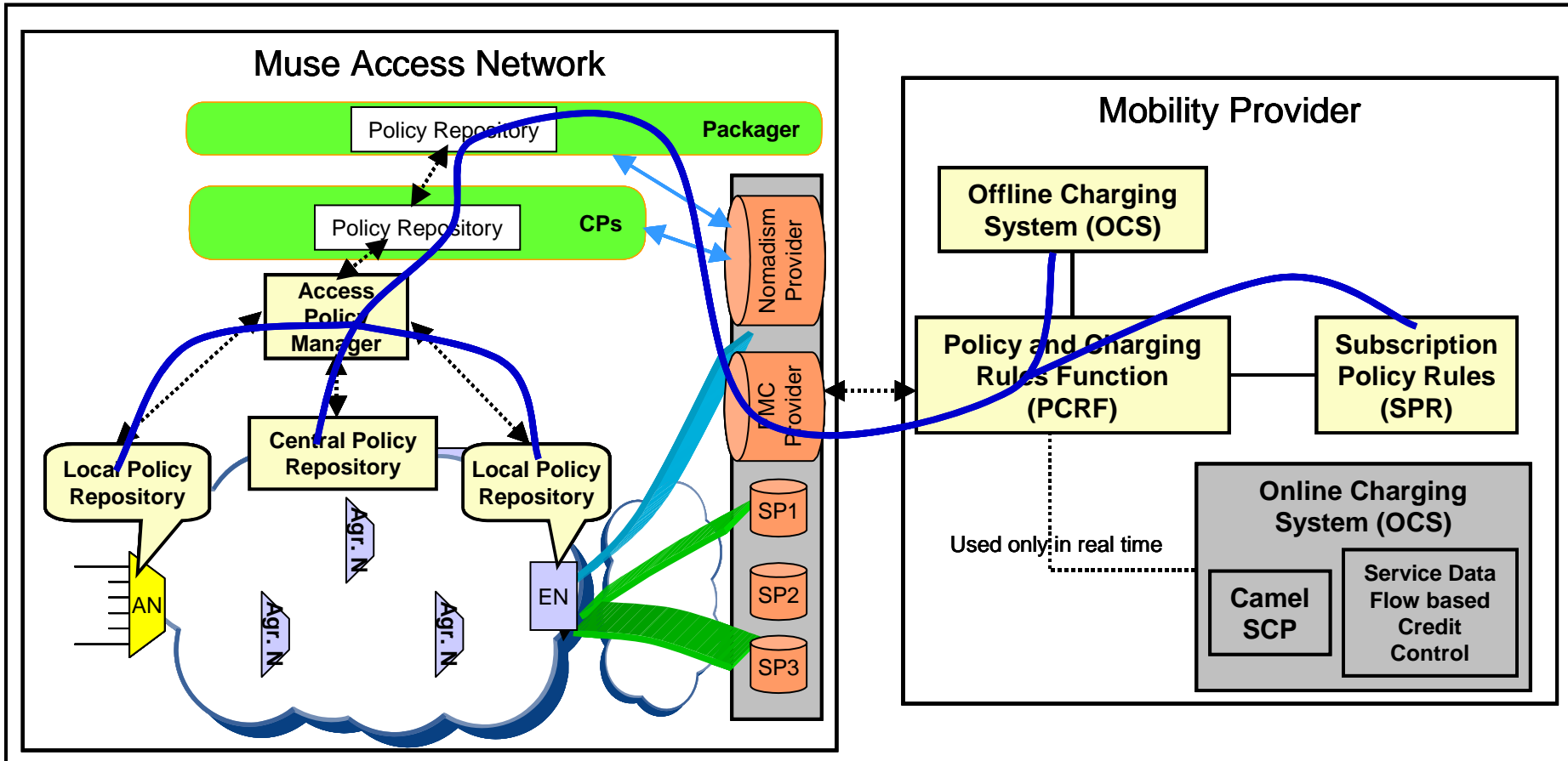

MUSE FMC Architecture – in progress!

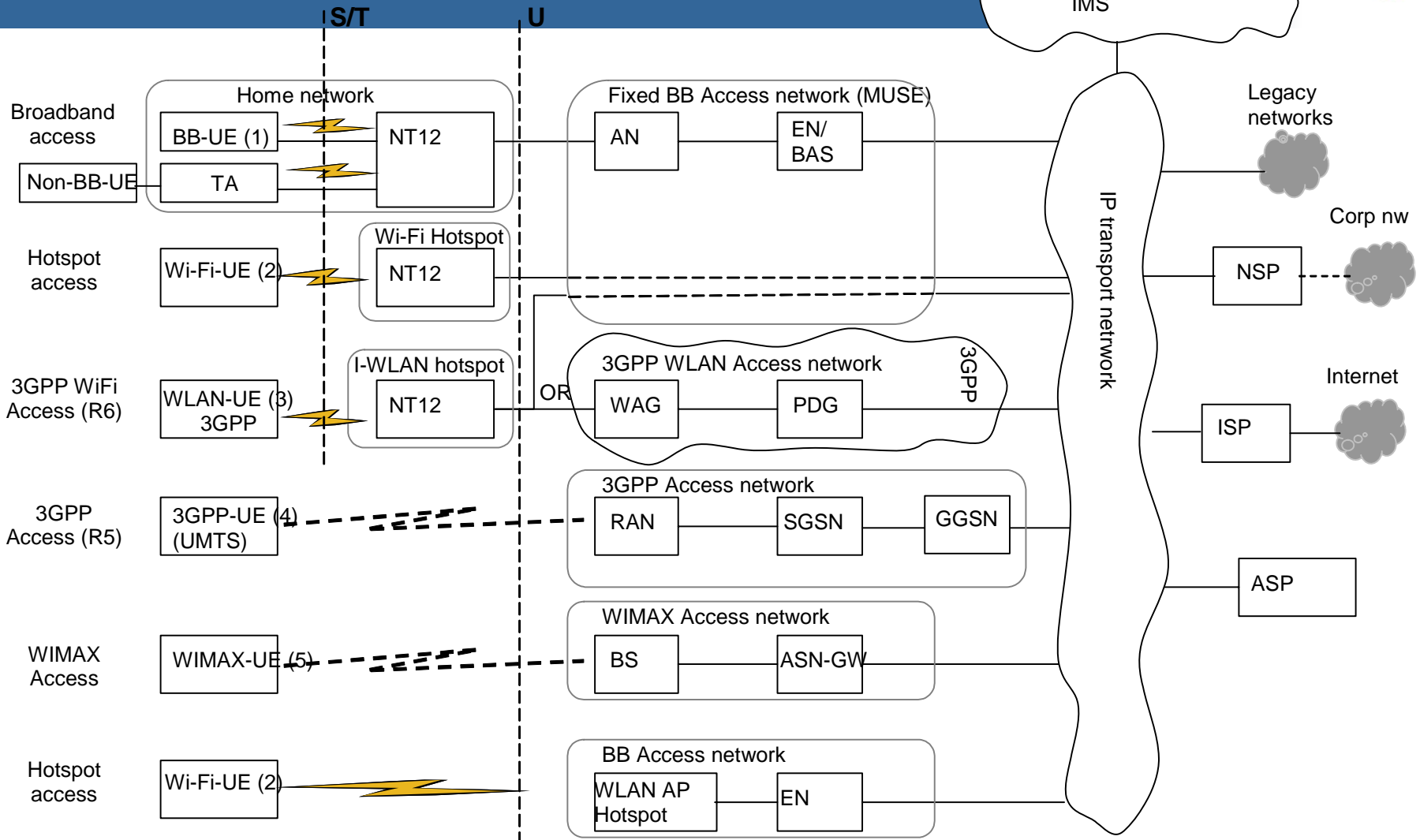

3GPP Multi-Access Architecture

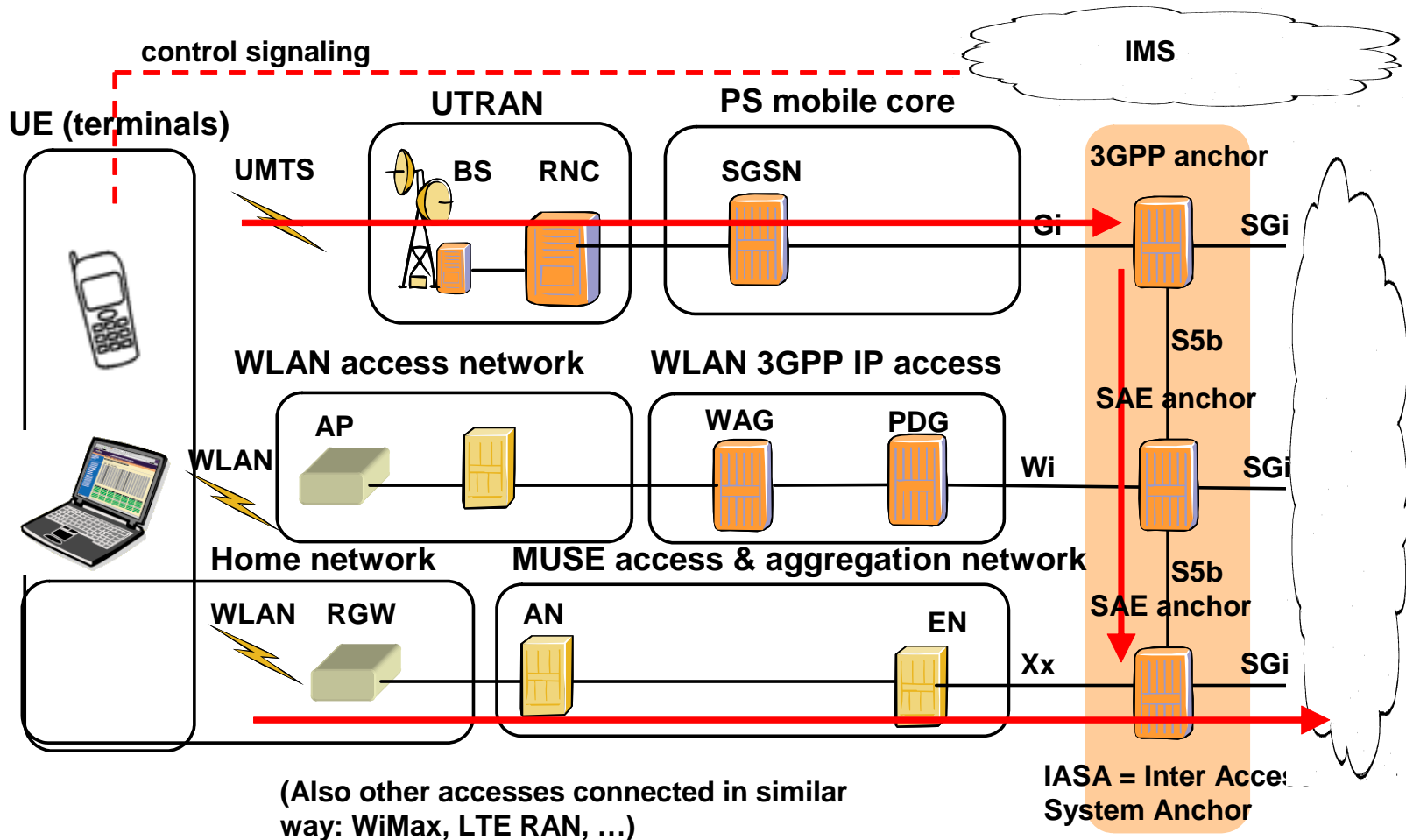

- > Mobility increase value for both provider and end user

- > Many technical challenges remain to be solved
 - Authentication
 - Session continuity
 - Roaming
 - Policy Control Framework
 - Common architecture

- > MUSE aims to solve this from a fixed access network provider perspective

References and further reading



- > Melander et al. "FMC from a Fixed Access Perspective", Mobile Summit 2006, Greece.
- > Mickelsson et al, "Nomadism/FMC Use Cases and AAA Impact", BBEurope, Geneva, 11-14 December 2006. – *To be presented*
- > Ericsson White paper – "Evolutions Towards Converged Services and Networks", http://www.ericsson.com/technology/whitepapers/convergence_b.pdf
- > FMCA - <http://thefmca.org/>
- > MUSE DA2.4, part D, <https://www.ist-muse.org>
- > MUSE DA1.3 "Advanced Application Requirements and User Behaviours ". Chapter 5 Fixed Mobile Convergence (FMC) and Nomadism.
- > Sprint White paper – "The Law of Mobility"